

Installation Note

4-Port Front Panel Upgrade Kit

To Upgrade 4-Port PNA-L “A” models to 4-Port PNA-L “C” models.

Upgrade Kit Order Number: N5230AU-241

For 4-Port PNA-L Models N5230A



Agilent Kit Number: N5230-60047

Agilent Document Number: N5230-90026

Printed in USA April 2008

© Agilent Technologies, Inc. 2008



N5230-90026

WARRANTY STATEMENT

THE MATERIAL CONTAINED IN THIS DOCUMENT IS PROVIDED “AS IS,” AND IS SUBJECT TO BEING CHANGED, WITHOUT NOTICE, IN FUTURE EDITIONS. FURTHER, TO THE MAXIMUM EXTENT PERMITTED BY APPLICABLE LAW, AGILENT DISCLAIMS ALL WARRANTIES, EITHER EXPRESS OR IMPLIED WITH REGARD TO THIS MANUAL AND ANY INFORMATION CONTAINED HEREIN, INCLUDING BUT NOT LIMITED TO THE IMPLIED WARRANTIES OF MERCHANTABILITY AND FITNESS FOR A PARTICULAR PURPOSE. AGILENT SHALL NOT BE LIABLE FOR ERRORS OR FOR INCIDENTAL OR CONSEQUENTIAL DAMAGES IN CONNECTION WITH THE FURNISHING, USE, OR PERFORMANCE OF THIS DOCUMENT OR ANY INFORMATION CONTAINED HEREIN. SHOULD AGILENT AND THE USER HAVE A SEPARATE WRITTEN AGREEMENT WITH WARRANTY TERMS COVERING THE MATERIAL IN THIS DOCUMENT THAT CONFLICT WITH THESE TERMS, THE WARRANTY TERMS IN THE SEPARATE AGREEMENT WILL CONTROL.

DFARS/Restricted Rights Notice

If software is for use in the performance of a U.S. Government prime contract or subcontract, Software is delivered and licensed as “Commercial computer software” as defined in DFAR 252.227-7014 (June 1995), or as a “commercial item” as defined in FAR 2.101(a) or as “Restricted computer software” as defined in FAR 52.227-19 (June 1987) or any equivalent agency regulation or contract clause. Use, duplication or disclosure of Software is subject to Agilent Technologies’ standard commercial license terms, and non-DOD Departments and Agencies of the U.S. Government will receive no greater than Restricted Rights as defined in FAR 52.227-19(c)(1-2) (June 1987). U.S. Government users will receive no greater than Limited Rights as defined in FAR 52.227-14 (June 1987) or DFAR 252.227-7015 (b)(2) (November 1995), as applicable in any technical data.

Safety Notes

The following safety notes are used throughout this document. Familiarize yourself with each of these notes and its meaning before performing any of the procedures in this document.

WARNING	Warning denotes a hazard. It calls attention to a procedure which, if not correctly performed or adhered to, could result in injury or loss of life. Do not proceed beyond a warning note until the indicated conditions are fully understood and met.
----------------	---

CAUTION	Caution denotes a hazard. It calls attention to a procedure that, if not correctly performed or adhered to, could result in damage to or destruction of the instrument. Do not proceed beyond a caution sign until the indicated conditions are fully understood and met.
----------------	---

Getting Assistance from Agilent

By internet, phone, or fax, get assistance with all your test and measurement needs.

Contacting Agilent

Assistance with test and measurements needs and information on finding a local Agilent office are available on the Web at:

<http://www.agilent.com/find/assist>

If you do not have access to the Internet, please contact your Agilent field engineer.

NOTE In any correspondence or telephone conversation, refer to the Agilent product by its model number and full serial number. With this information, the Agilent representative can determine whether your product is still within its warranty period.

Description of the Upgrade

This upgrade changes the front panel UI (user interface) of your 4-port N5230A PNA-L to a touchscreen and softkey interface with a new color LCD display. This is done by removing the existing front panel assembly, removing the internal floppy disk drive (the new front panel assembly does not allow for a floppy disk drive), and installing a new front panel assembly.

After installation of this upgrade, your analyzer will be a “C” model rather than an “A” model.

About Installing the Upgrade

Products affected	4-port N5230A with firmware revision code A.07.50 or higher. ^a
Installation to be performed by	Agilent service center or personnel qualified by Agilent
Estimated installation time	4.0 hours
Estimated adjustment time	0.5 hours
Estimated full instrument calibration time	4.5 hours

a. If your analyzer does not have the necessary firmware revision (or if you are not sure), go to “[Check/Upgrade Your Analyzer’s Firmware Revision Code](#)” on page 4 for information on checking and upgrading it.

Check/Upgrade Your Analyzer's Firmware Revision Code

For the new front panel and user interface to function properly, your analyzer's firmware revision code must be A.07.50 or higher. Refer to the following paragraphs to check your analyzer's current firmware revision code and, if necessary, to upgrade it.

How to Check the Current Firmware Version

1. With the **Network Analyzer** application running, click **Help, About Network Analyzer**.
A dialog box showing the current installed Application Code Version is displayed.
2. To determine if a firmware update is available, proceed to "[Downloading from the Internet](#)."

Downloading from the Internet

If your network analyzer is connected to the Internet, there are two methods available for checking the availability of, and downloading, new firmware:

- Download directly from: <http://www.agilent.com/find/pna>. (Select your analyzer's model number in this web site to view available upgrades.)
- On the **System** menu, point to **Service**, and then click **AgileUpdate**. **AgileUpdate** compares the firmware revision currently installed in your network analyzer to the latest version available and assists you in downloading and installing the most recent version. This is available only on analyzers with firmware revision A.01.20 and higher.

Items Included in the Upgrade Kit

Check the contents of your kit against the following list. If any part is missing or damaged, contact Agilent Technologies. Refer to [“Getting Assistance from Agilent” on page 3](#).

Table 1 Contents of Upgrade Kit N5230-60047 (For 4-port N5230A)

Description	Qty	Part Number
Installation note (this document)	1	N5230-90026
ROHS addendum	1	9320-6722
Front panel assembly	1	N5230-60044
Front dress panel	1	N5230-00015
Machine screw, 90-deg flat head, M3 x 4 mm (to attach front dress panel)	10	0515-4791
Hard disk drive, imaged for new front panel assembly	1	N5230-10048
Floppy disk containing upgrade installation program for the CPU board	1	N5230-10001
Nameplate: N5230C 300 kHz - 13.5 GHz (For Option 140, 145, or 146.)	1	N5230-80020
Nameplate: N5230C 300 kHz - 20 GHz (For Option 240, 245, or 246.)	1	N5230-80021
Lower front panel overlay; Option 140 or 240	1	N5230-80006
Lower front panel overlay; Option 145, 146, 245, or 246	1	N5230-80007
Jumper (for CPU board connector)	1	1258-0209

Installation Procedure for the Upgrade

The network analyzer must be in proper working condition prior to installing this option. Any necessary repairs must be made before proceeding with this installation.

WARNING **This installation requires the removal of the analyzer’s protective outer covers. The analyzer must be powered down and disconnected from the mains supply before performing this procedure.**

Electrostatic Discharge Protection

Protection against electrostatic discharge (ESD) is essential while removing or connecting cables or assemblies within the network analyzer.

Static electricity can build up on your body and can easily damage sensitive internal circuit elements when discharged. Static discharges too small to be felt can cause permanent damage. To prevent damage to the instrument:

- *always* have a grounded, conductive table mat in front of your test equipment.
- *always* wear a grounded wrist strap, connected to a grounded conductive table mat, having a 1 M Ω resistor in series with it, when handling components and assemblies or when making connections.
- *always* wear a heel strap when working in an area with a conductive floor. If you are uncertain about the conductivity of your floor, wear a heel strap.
- *always* ground yourself before you clean, inspect, or make a connection to a static-sensitive device or test port. You can, for example, grasp the grounded outer shell of the test port or cable connector briefly.

Figure 1 shows a typical ESD protection setup using a grounded mat and wrist strap. Refer to “ESD Equipment and Supplies Required for the Installation” on page 7 for part numbers.

Figure 1 ESD Protection Setup

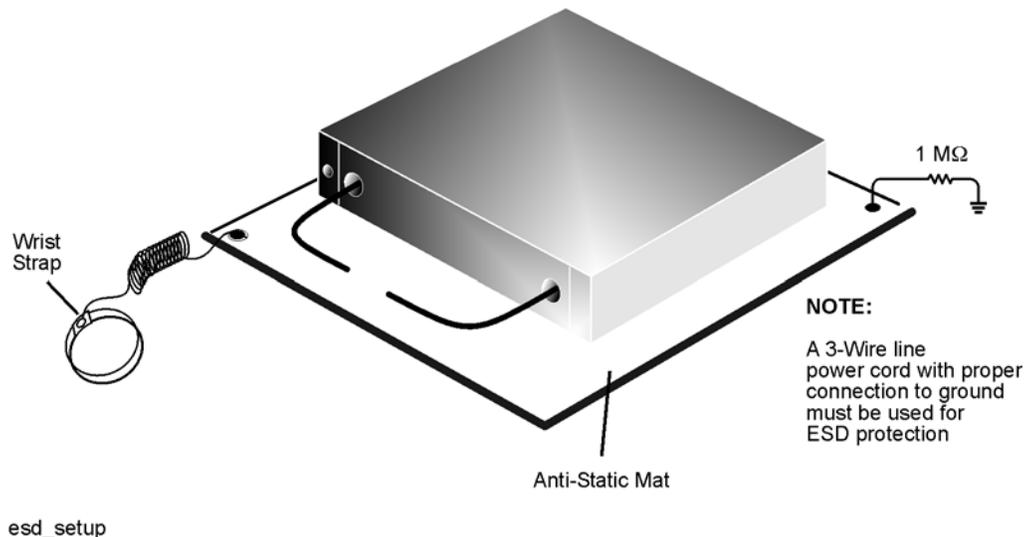

Tools Required for the Installation

Description	Agilent Part Number
T-10 TORX driver (set to 9 in-lbs)	N/A
T-20 TORX driver (set to 21 in-lbs)	N/A
5/16-inch torque wrench (set to 10 in-lbs)	N/A

ESD Equipment and Supplies Required for the Installation

Description	Agilent Part Number
ESD grounding wrist strap	9300-1367
5-ft grounding cord for wrist strap	9300-0980
2 x 4 ft conductive table mat and 15-ft grounding wire	9300-0797
ESD heel strap (for use with conductive floors)	9300-1308

Overview of the Installation Procedure

- Step 1. Copy All Unique Files to an External Disk Drive.
- Step 2. Remove the Hard Disk Drive Assembly (HDDA).
- Step 3. Flash the BIOS Using the Floppy Disk Provided.
- Step 4. Remove the Outer and Inner Covers.
- Step 5. Remove the Front Panel Assembly.
- Step 6. Remove the Floppy Disk Drive.
- Step 7. Install the Dress Panel on the New Front Panel Assembly.
- Step 8. Install the New Overlays on the New Front Panel Assembly.
- Step 9. Install the New Front Panel Assembly.
- Step 10. Modify the CPU Board.
- Step 11. Install the New Hard Disk Drive (HDD).
- Step 12. Reinstall the Inner and Outer Covers.
- Step 13. Copy the Unique Files Back to the Analyzer's HDD.
- Step 14. Perform Post-Upgrade Adjustments and Calibration.

Step 1. Copy All Unique Files to an External Disk Drive

The hard disk drive (HDD) in your analyzer will be replaced as part of this upgrade. Therefore, it is necessary that all unique and personal files stored on the HDD be saved to an external disk drive for reinstallation later on the new HDD.

This procedure is written assuming a USB flash memory drive is used, although any external disk drive will suffice.

1. Connect the power cord to the analyzer and turn ON the power.
2. Insert a USB flash memory drive into a USB port.
3. Open **Windows Explorer**.
4. Navigate to C:\Program Files\Agilent\Network Analyzer.
5. Copy each of the following files from the hard disk drive to the USB drive:
 - gen.lic
 - user_calfile
 - All files prefixed with mxcalfile_.
 - Any personal user files that you wish to preserve.
6. Remove the USB drive from the USB port.
7. Exit **Windows Explorer**.

Step 2. Remove the Hard Disk Drive Assembly (HDDA)

1. With a T-10 TORX driver, loosen the four HDDA mounting screws (item ①) on the rear panel.
2. Remove the HDDA from the analyzer by pulling on the finger grip (item ②). The HDDA interconnects with a connector inside the analyzer rear panel so moderate force may be necessary to disengage this connector.
3. Set the HDDA aside. It will have a new hard disk drive (HDD) installed and then be reinstalled in the analyzer later in this upgrade procedure.

Figure 2 Hard Disk Drive Assembly Removal

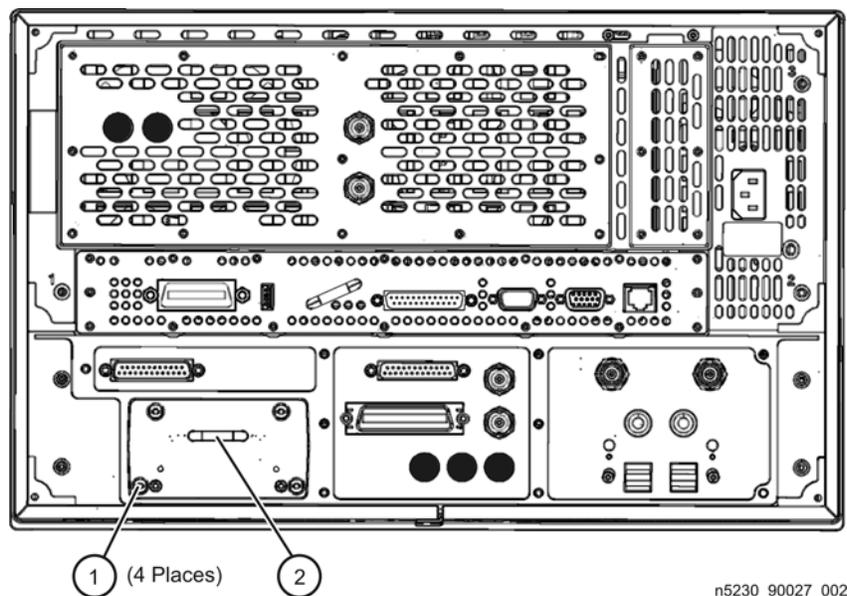

Step 3. Flash the BIOS Using the Floppy Disk Provided

1. Reconnect the power cord to the analyzer and turn ON the power.
2. Connect a keyboard to the analyzer.
3. Insert the floppy disk provided into the analyzer's floppy disk drive.
4. The analyzer will boot from the floppy disk and a program will run to flash the BIOS. Be sure to follow all instructions as they are displayed.
5. When the procedure is done, turn OFF the power to the analyzer and disconnect the power cord and the keyboard.

Step 4. Remove the Outer and Inner Covers

Remove the Outer Cover

1. Turn OFF the analyzer and disconnect the power cord.
2. With a T-20 TORX driver, remove the strap handles (item ①) by loosening the screw (item ②) on each end of each handle.
3. With a T-20 TORX driver, remove the four rear panel feet (item ③) by removing the center screws (item ④).
4. Slide the four bottom feet (item ⑤) off the cover.
5. Slide the cover off of the frame.

Figure 3 Outer Cover Removal

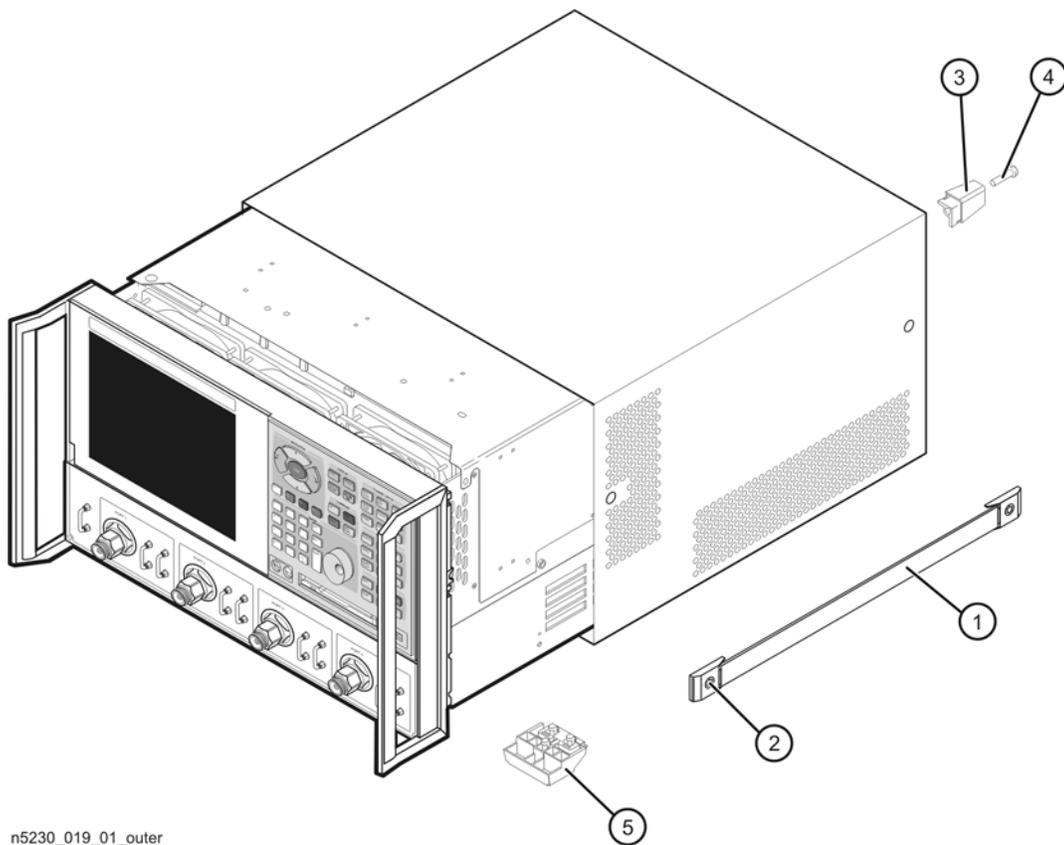

n5230_019_01_outer

Remove the Inner Cover

1. Place the analyzer top-side up on a flat surface.
2. Using a T-10 TORX driver, remove all of the attachment screws (item ①). There may be either 11 or 12 attachment screws.
3. Lift off the cover.

Figure 4 Inner Cover Removal

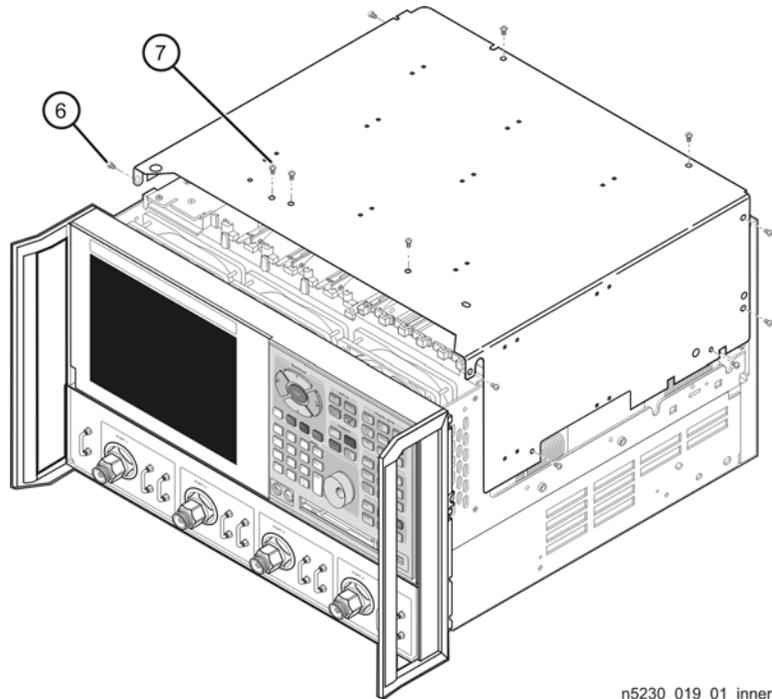

n5230_019_01_inner

Step 5. Remove the Front Panel Assembly

1. With a 5/16-inch wrench, remove all semi-rigid jumpers (item ①) from the front panel.
2. With a T-10 TORX driver, remove the eight screws (item ②) from the sides of the frame.

CAUTION Before removing the front panel from the analyzer, lift and support the front of the analyzer chassis.

3. Slide the front panel over the test ports and other front panel connectors.
4. Disconnect the front panel interface ribbon cable (item ③). The front panel is now free from the analyzer.

Figure 5 Front Panel Assembly Removal

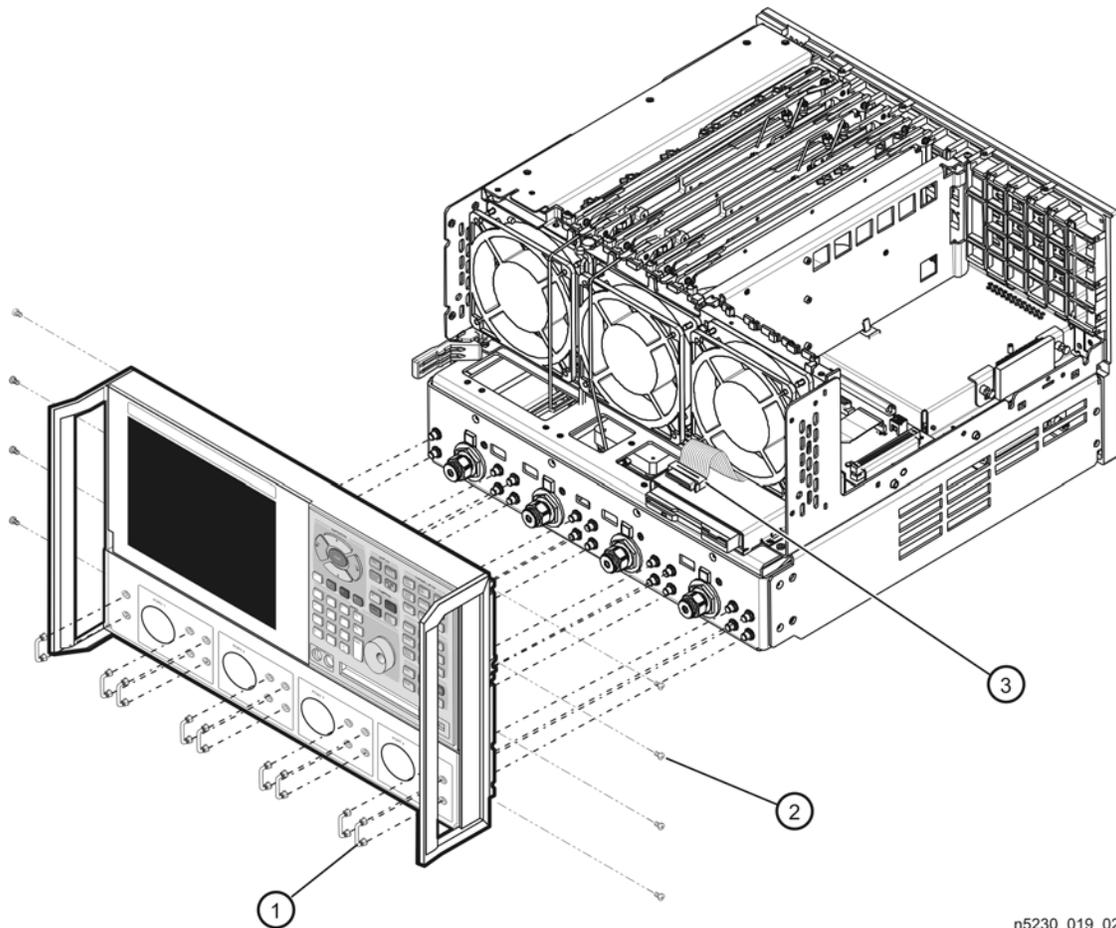

n5230_019_02

Step 6. Remove the Floppy Disk Drive

1. Disconnect the ribbon cable (item ①) from the A14 system motherboard.
2. Lift the tab at the rear of the A40 floppy disk drive enclosure and remove the rear enclosure cover (item ②).
3. Slide the A40 floppy disk drive out of the front of the enclosure. The A40 floppy disk drive fits snugly. You may have to push the drive from the back to remove it from the analyzer.
4. All floppy disk drive parts removed may be discarded, they are no longer needed.

Figure 6 Floppy Disk Drive Removal

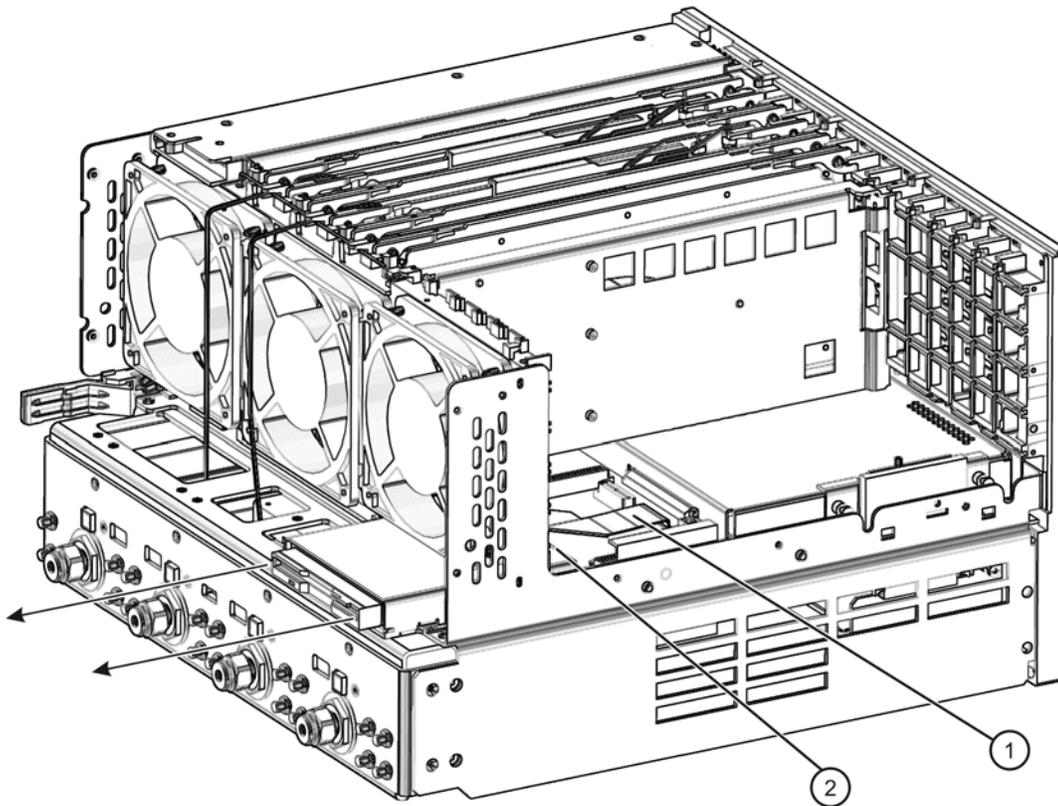

n5230_013_714

Step 7. Install the Dress Panel on the New Front Panel Assembly

1. Install the new lower dress panel onto the new front panel using the 10 flat head screws (item ①) provided.

Figure 7 Front Dress Panel Installation

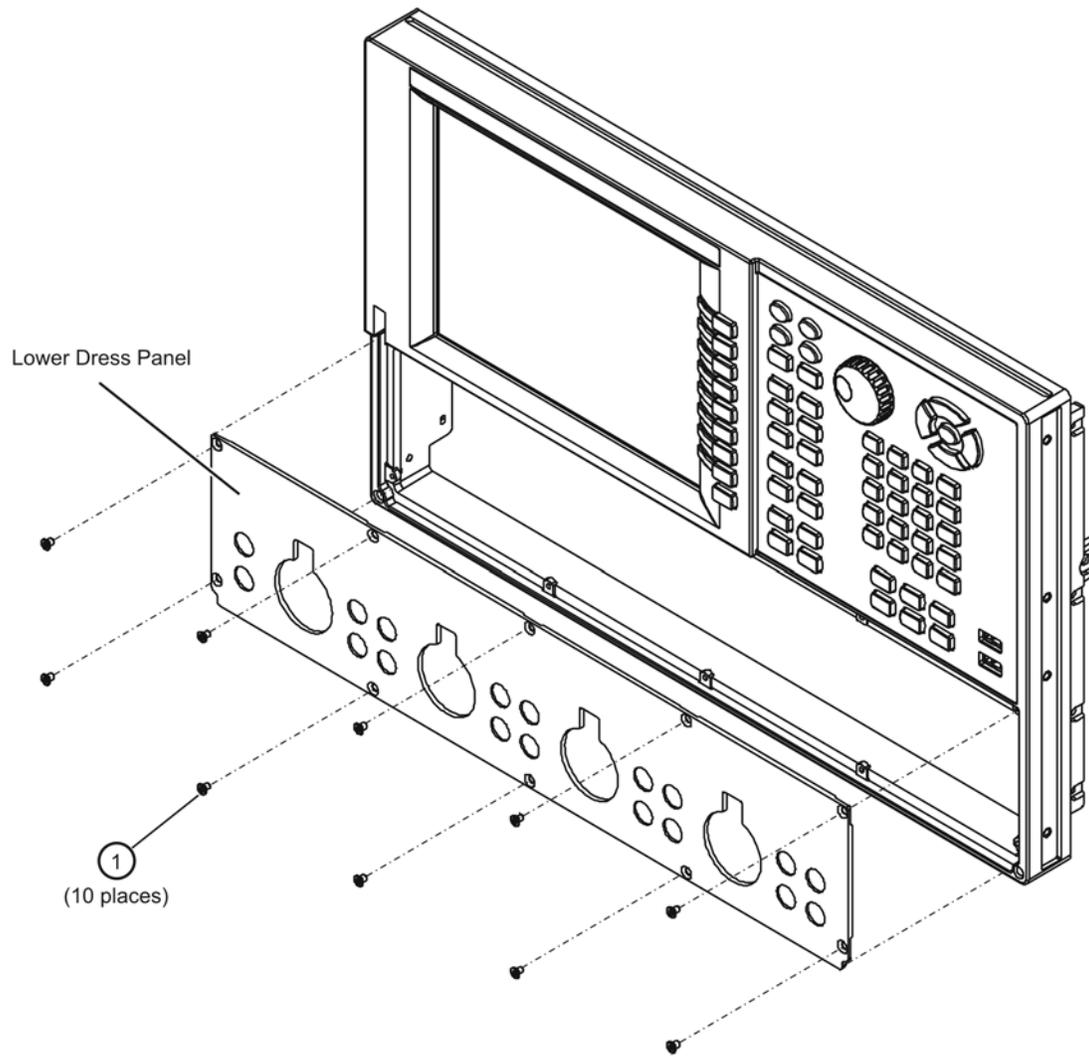

n5230_90026_014

Step 8. Install the New Overlays on the New Front Panel Assembly

1. There should be a lower front panel overlay included with the kit that matches the overlay on your analyzer's old front panel. There are multiple overlays provided in the kit; be sure that you use the proper one for your analyzer. If there is not an overlay that matches your analyzer, contact Agilent. Refer to [“Contacting Agilent” on page 3](#) of this installation note.
2. There should also be a nameplate overlay included with the kit that matches your new analyzer; the same number as the old one except it will be a “C” model. There are multiple overlays provided in the kit; be sure that you use the proper one for your analyzer. If there is not an overlay that matches your analyzer, contact Agilent. Refer to [“Contacting Agilent” on page 3](#) of this installation note.
3. Install each of the overlays as follows:
 - Remove the protective backing to expose the adhesive.
 - Carefully align the overlay to its location and gently position it.
 - Once the overlay is properly positioned, press it firmly into place.

Figure 8 Front Panel Overlays Installation

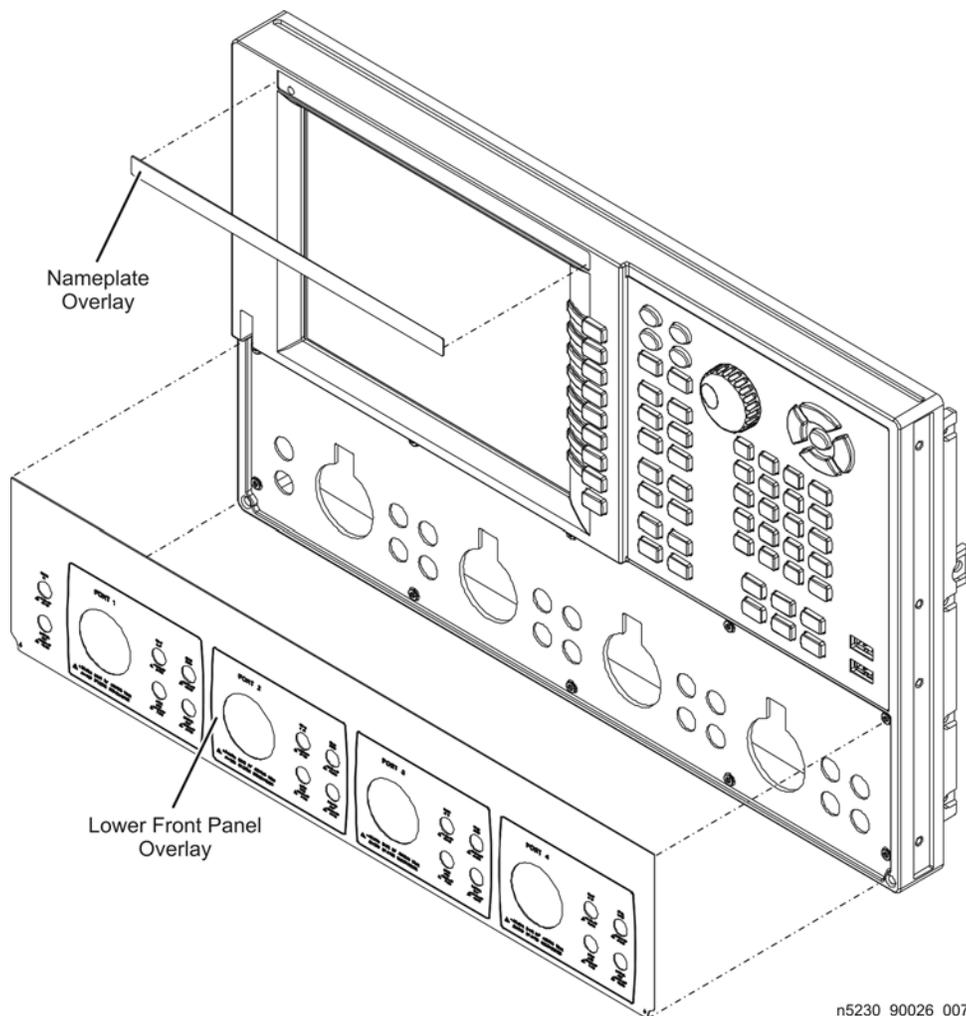

Step 9. Install the New Front Panel Assembly

CAUTION Before installing the front panel assembly onto the analyzer, place the analyzer right side up and lift and support the front of the analyzer chassis.

1. Reconnect the ribbon cable (item ③) to the A3 front panel interface board.
2. Slide the front panel over the test port connectors being careful to align the power switch push button to its front panel cutout. Ensure that the ribbon cable (item ③) is located below the fan to prevent it from being damaged by the fan blades.
3. With a T-10 TORX driver, install the eight screws (item ②) in the sides of the frame.
4. If equipped with front panel jumpers, reinstall the semi-rigid jumpers (item ①) on the front panel using a 5/16 inch torque wrench set to 10 in-lbs

Figure 9 New Front Panel Assembly Installation

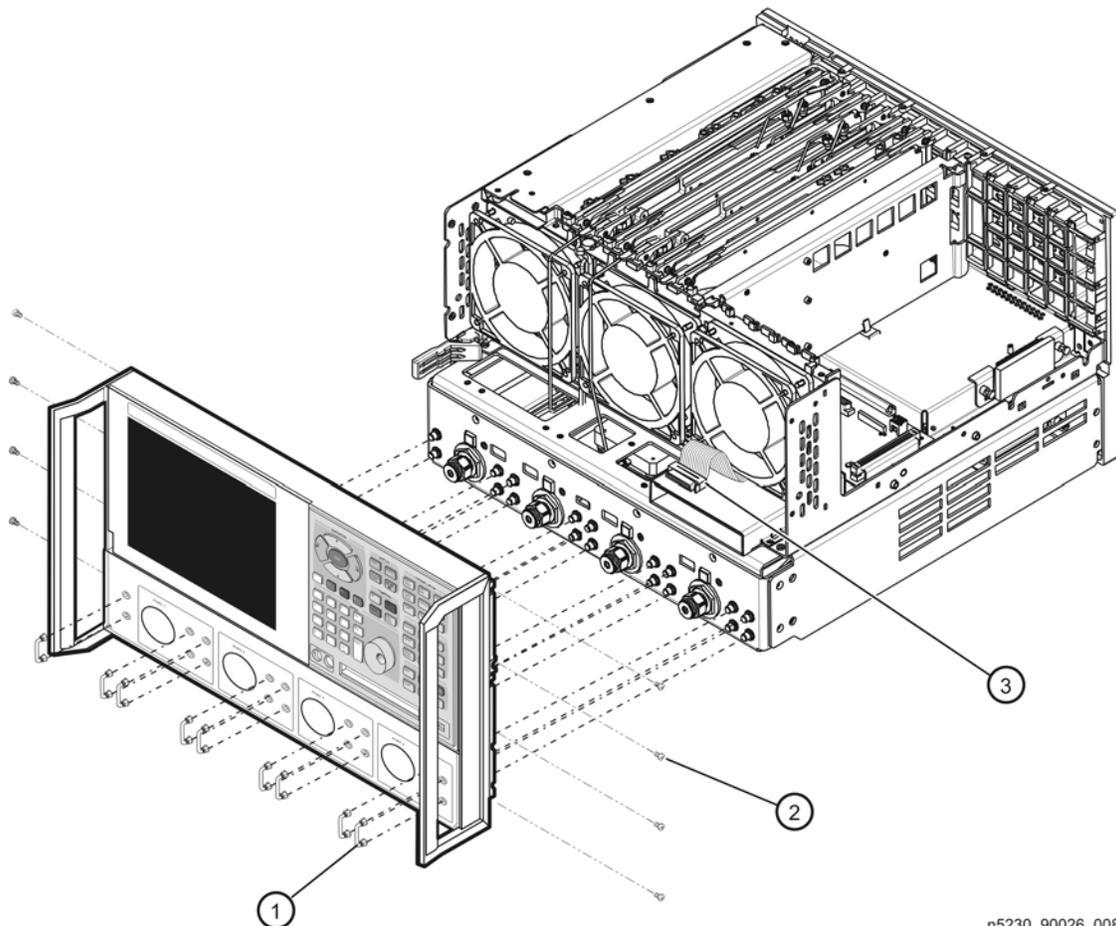

n5230_90026_008

Step 10. Modify the CPU Board

Remove the CPU Board

1. Disconnect the hard disk drive assembly (HDDA) ribbon cable and interface board from the A15 CPU board by removing the two screws (item ①).
2. Disengage the SPAM board from the A15 CPU board by performing the following steps.
 - a. Lift the two extractors located at each end of the board.
 - b. While holding onto the extractors, lift the board halfway out of the slot.
 - c. Let the extractors drop to their normal position.
 - d. Lower the board into the slot.The board should now rest above its normal seated position.
3. With a T-10 TORX driver, remove the 14 screws (item ②) from the rear panel of the A15 CPU board.
4. Gently pull on the finger grip (item ③) to disengage the A15 CPU board from the analyzer.
5. Slide the A15 CPU board out of the analyzer.

Figure 10 CPU Board Removal

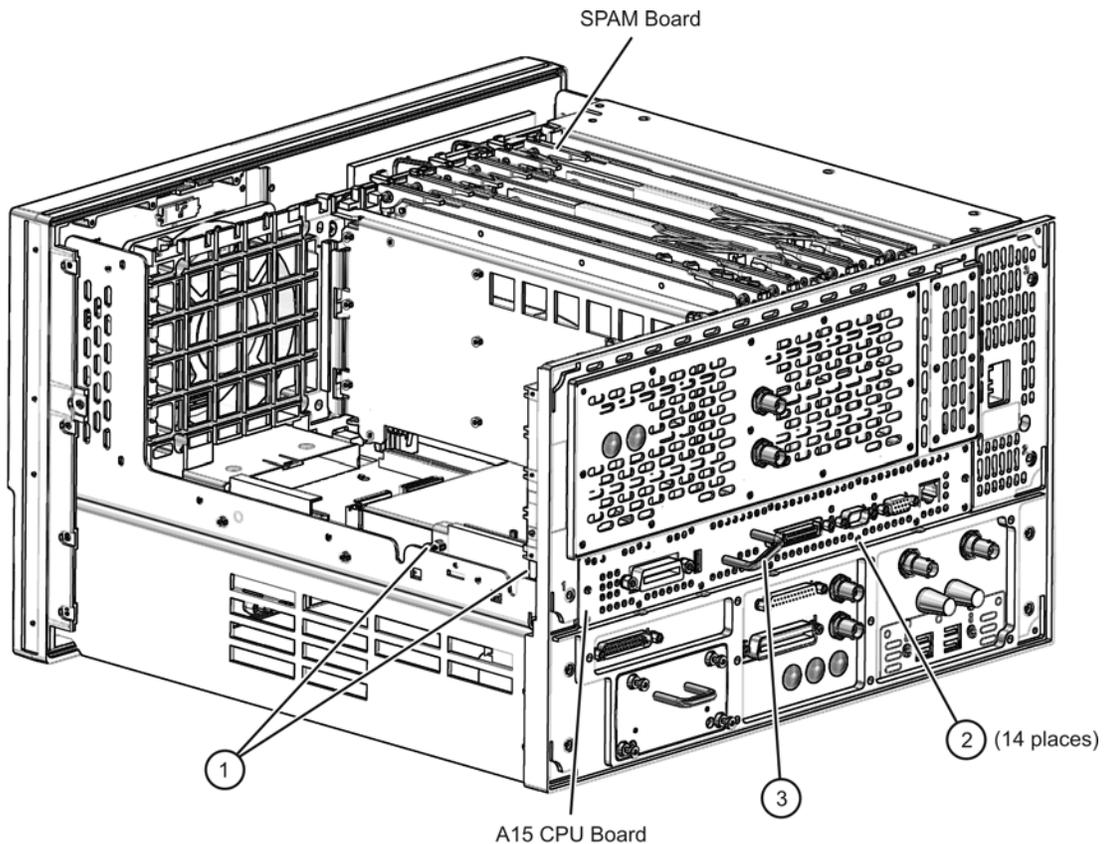

n5230_90027_009

Install a Jumper on CPU Board Connector J11

1. Install a jumper between pins 9 and 10 of connector J11 as shown in the illustration.
NOTE: There should already be a jumper between pins 5 and 6.

Figure 11 Jumper Installation

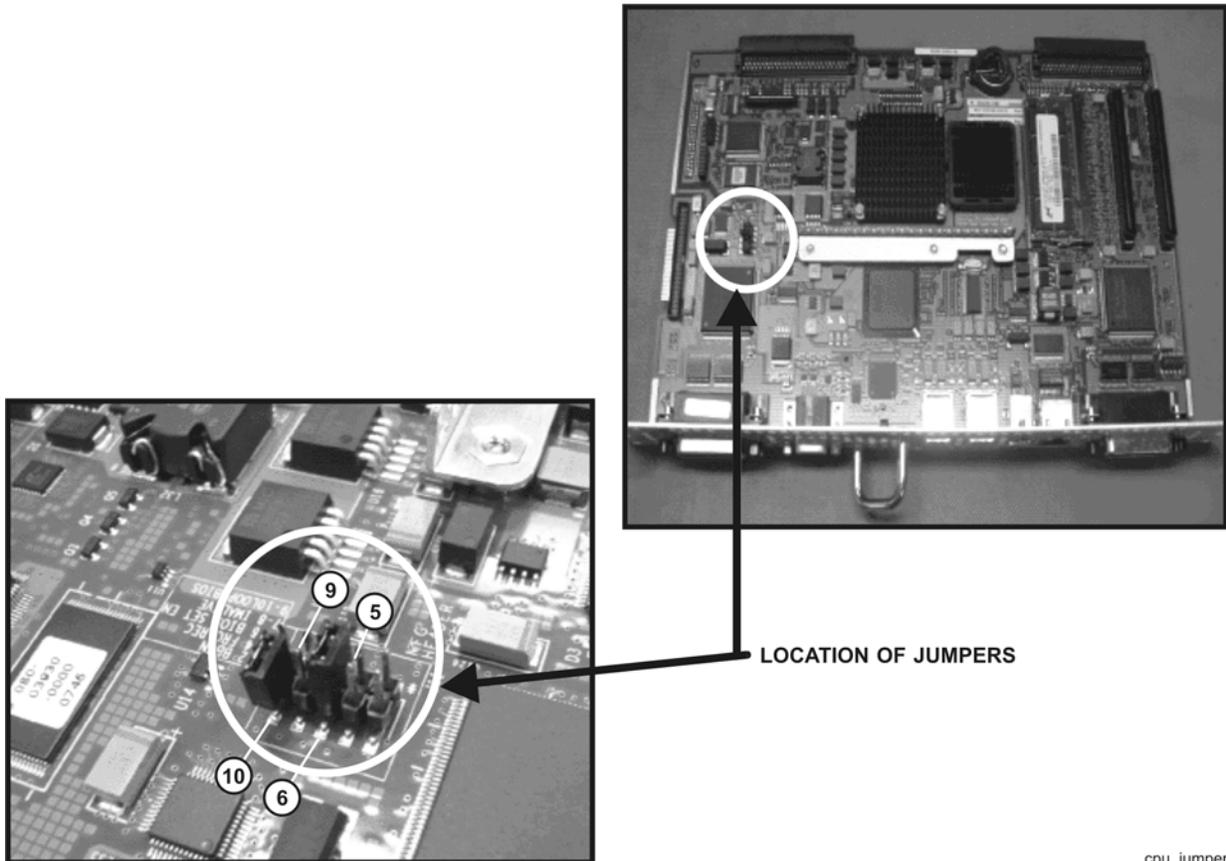

Reinstall the CPU Board

1. Reinstall the CPU board by reversing the procedure on [page 18](#) used to remove the board.

Step 11. Install the New Hard Disk Drive (HDD)

Replace the HDD

1. With a T-10 TORX driver, remove the four screws (item ①), and the eight bushings (item ②), that mount the HDD (item ④), to the bracket.
2. Disconnect the HDD (item ④) from the interface board (item ③).
3. Install the new HDD by reversing the above steps.

Reinstall the Hard Disk Drive Assembly (HDDA) in the Analyzer

1. Reinstall the HDDA in the analyzer by reversing the procedure on [page 9](#) used to remove the HDDA.

Figure 12 Hard Disk Drive (HDD) Replacement

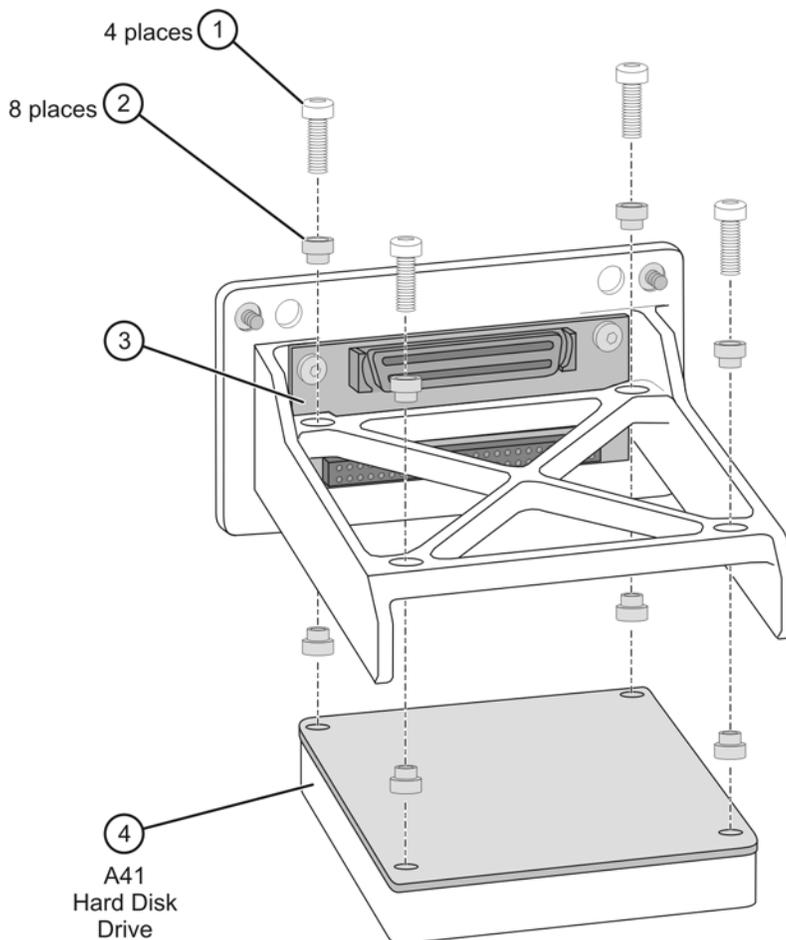

n5230_90027_011

Step 12. Reinstall the Inner and Outer Covers

Reinstall the Inner Cover

1. Place the inner cover on the analyzer as shown. There are two alignment pins on the front frame that align with holes in the front of the cover to ensure proper alignment.
2. Using a T-10 TORX driver, reinstall the attachment screws (item ①). There may be either 11 or 12 attachment screws.

Figure 13 Inner Cover Reinstallation

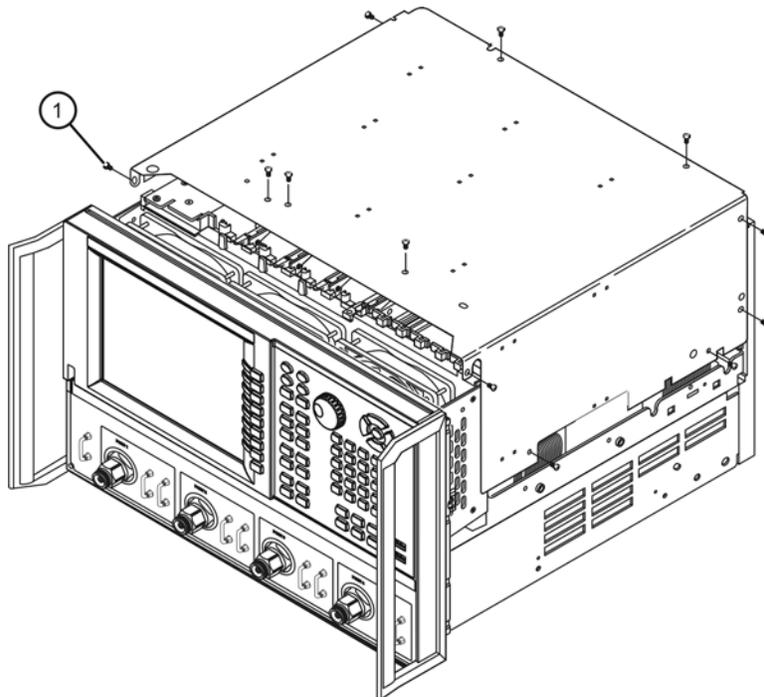

n5230_90026_012

Reinstall the Outer Cover

1. Slide the cover onto the frame.
2. Using a T-20 TORX driver, install the four rear panel feet (item ③) by installing the center screws (item ④).
3. Slide the four bottom feet (item ⑤) onto the cover.
4. Using a T-20 TORX driver, install the strap handles (item ①) by tightening the screws (item ②) on both ends.

Figure 14 Outer Cover Reinstallation

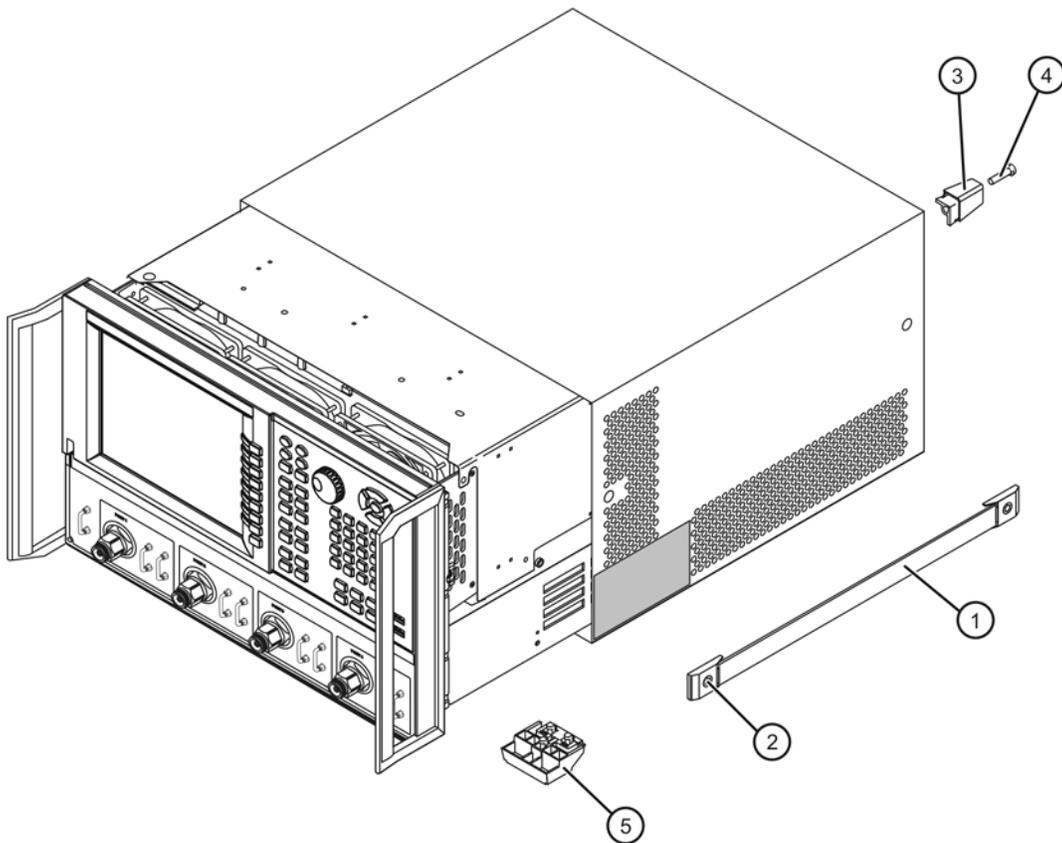

n5230_90026_013

Step 13. Copy the Unique Files Back to the Analyzer's HDD

The files that were previously saved onto a USB flash memory drive must now be installed onto the new HDD.

1. Connect the power cord to the analyzer and turn ON the power.
2. Insert the USB flash memory drive into a USB port.
3. Open **Windows Explorer**.
4. Navigate to C:\Program Files\Agilent\Network Analyzer.
5. Copy each of the backup files from the USB flash memory drive to the HDD.
6. Navigate to D:\CalFiles\.
7. Copy the backup files prefixed with mxcalfile_ from the USB flash memory drive to the HDD.
8. After all files have been copied, remove the USB flash memory drive from the USB port.
9. Exit **Windows Explorer**.

Step 14. Perform Post-Upgrade Adjustments and Calibration

Adjustments

The following adjustments must be made due to the hardware changes of the analyzer.

- source calibration
- receiver calibration

These adjustments are described in the PNA Service Guide and in the PNA on-line HELP. A list of equipment required to perform these adjustments is also found in the service guide.

To view the Service Guide online, use the following steps:

1. Go to www.agilent.com.
2. In the Search box, enter the model number of your analyzer (for example E8361A) and click **Search**.
3. Click [Technical Support > Manuals](#).
4. Click [Service Manual](#).
5. Click the service guide title to load the PDF file.
6. When the PDF of the Service Guide is displayed, scroll through the Contents section bookmarks to locate the “Tests & Adjustments” chapter.

After the specified adjustments have been performed, the analyzer should operate and phase lock over its entire frequency range.

Operator’s Check

Perform the Operator’s Check to check the basic functionality of the analyzer. For instructions, refer to the “Tests & Adjustments” chapter of the Service Guide.

If you experience difficulty with the basic functioning of the analyzer, contact Agilent. Refer to [“Contacting Agilent” on page 3](#).

Calibration

Although the analyzer functions, its performance relative to its specifications has not been verified. It is recommended that a full instrument calibration be performed using the N7840A performance test software. Refer to the analyzer’s service guide for information on the performance test software.